



The Shadow of the Moon in IceCube

Laura Gladstone
University of Wisconsin, Madison
for the IceCube Collaboration

Young Scientists Forum
46th Rencontres de Moriond
La Thuile, Italy
18 March 2011



Motivation: we know where it is, 2/9

Northern hemisphere: atmospheric neutrino background

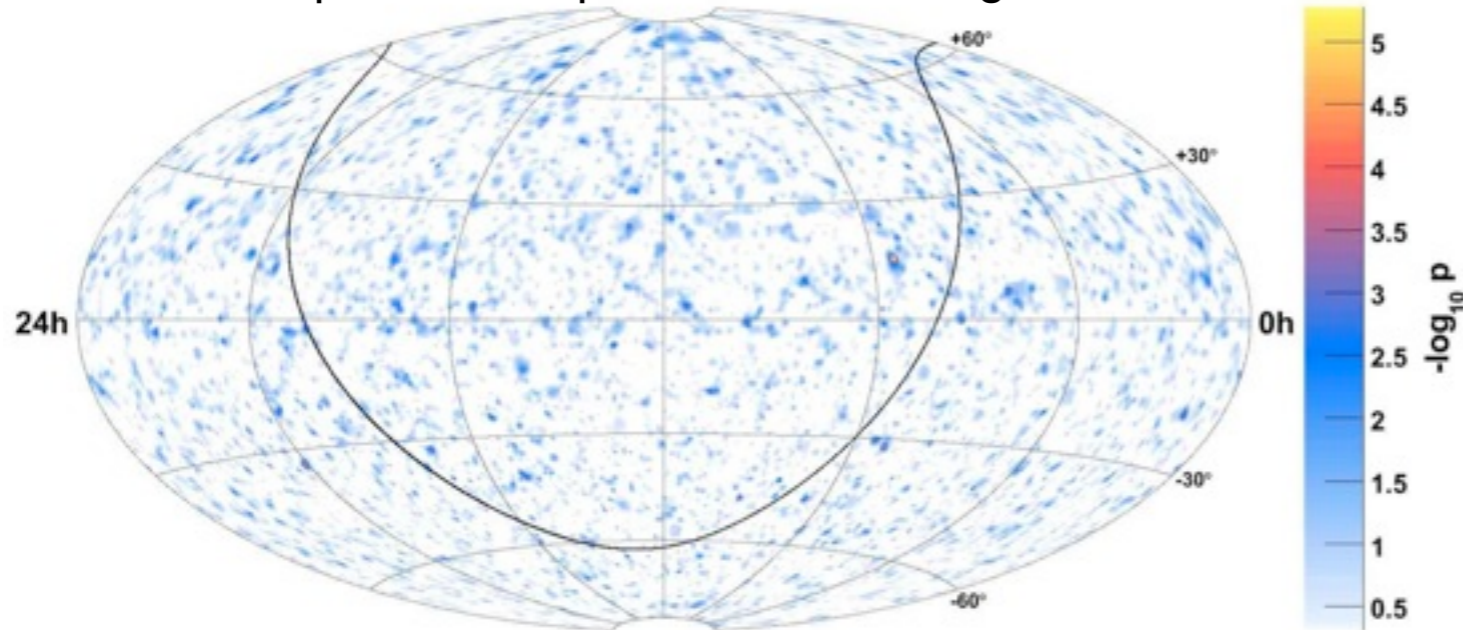

IceCube is an observatory, but instead of light we use neutrinos to look into space.

To resolve stars, we must first be able to resolve the Moon.

This is an End-to-end check of detector systematics and pointing.

Southern hemisphere: cosmic ray muon background
Accepted ApJ, arXiv: 1012.2137 [astro-ph]

If IceCube wants skymaps to look like this...



Hubble Space Telescope Star Cluster NGC 290

Caveat: we look for astrophysical point sources in neutrinos, but we look for the Moon in downgoing muons.

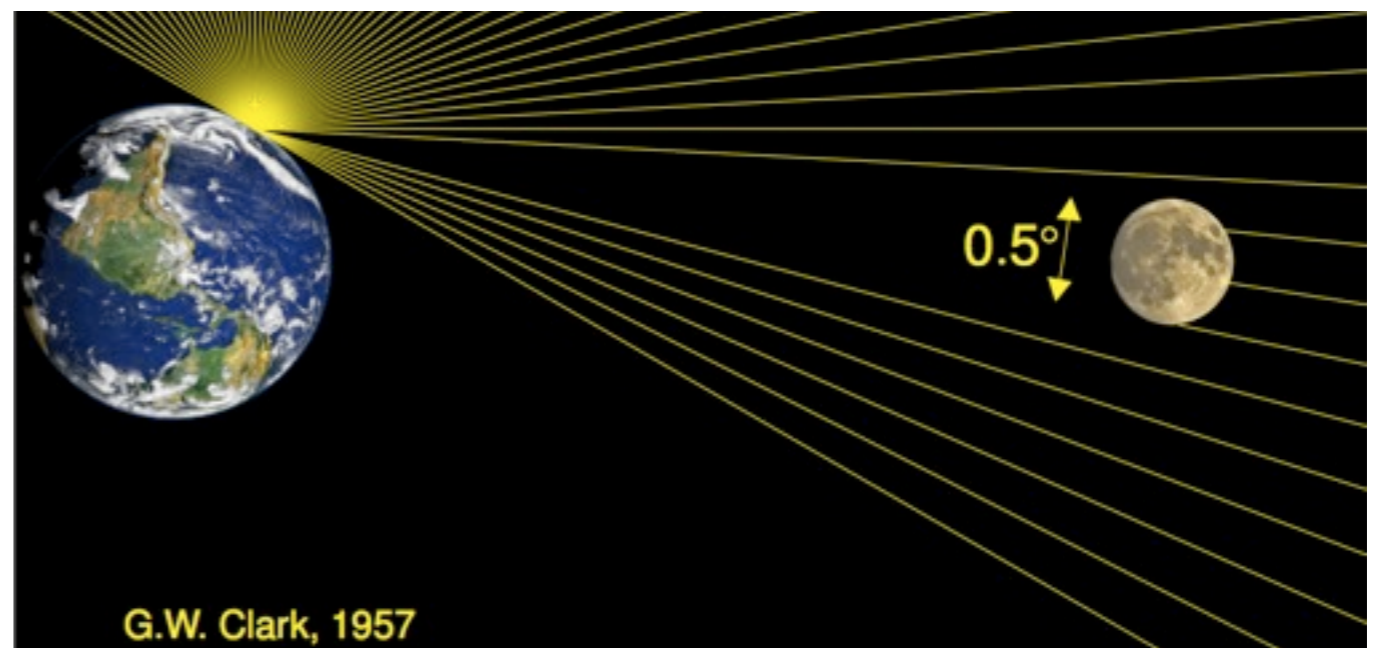

G.W. Clark, 1957

Analysis History

IceCube Moon Shadow Analyses **shown here**

22	2.7 σ	Binned	L. Gladstone	COSMO08 poster
40	7.5 σ	binned: ask about backup slides	L. Gladstone	ICRC proc. 2009, arXiv:1002.4900
59	12 σ	Unbinned	H. Stiebel	Masters Thesis 2011, Stockholm
40, 59	8 σ , 12 σ	Likelihood	J. Blumenthal	Diplomarbeit 2011, Aachen

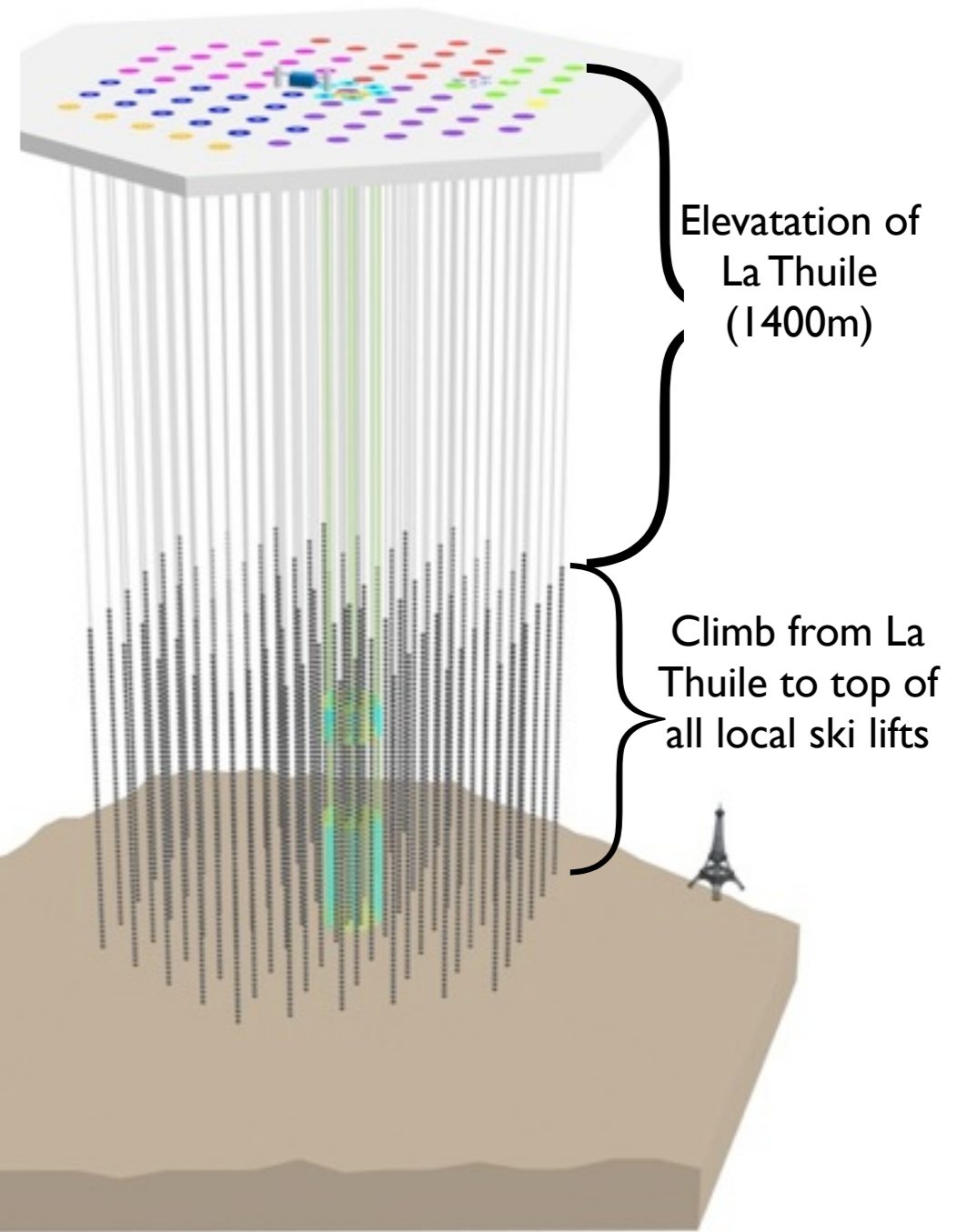

↑
Number of strings in IceCube during this data set, out of 86

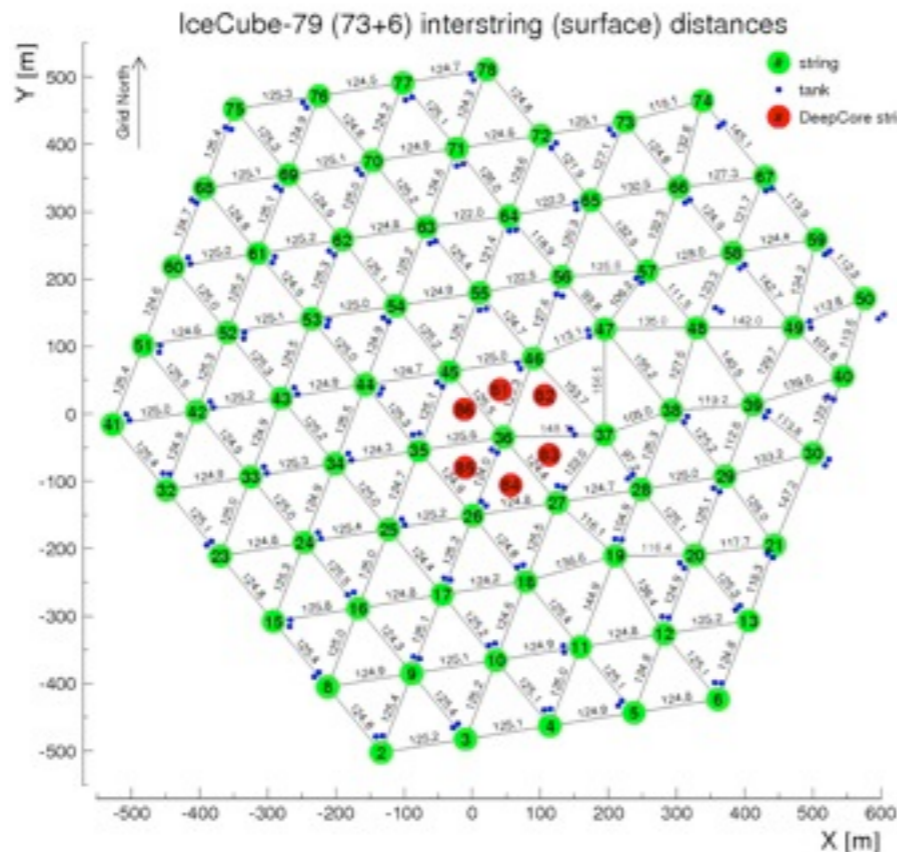

Data Sample

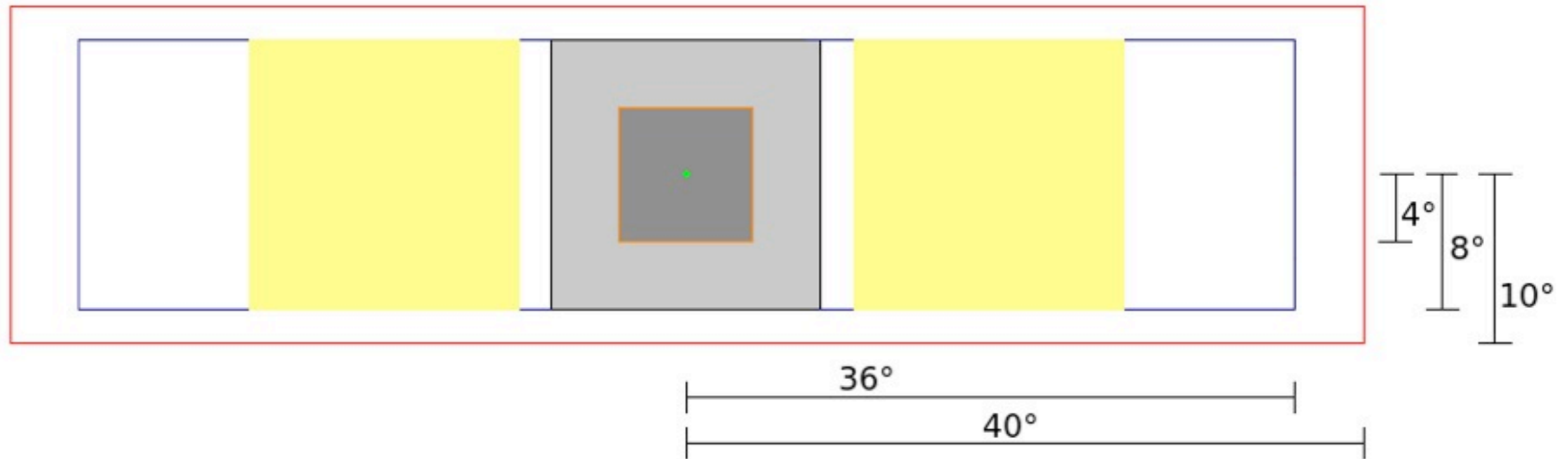

- Use events from a window around the Moon for both signal and background measurement
- Angular resolution of IceCube is comparable to the size of the Moon
- Minimum energy of primary cosmic ray: 2 TeV

one example event: $\text{err}_1 = 0.4^\circ$
 $\text{err}_2 = 0.8^\circ$

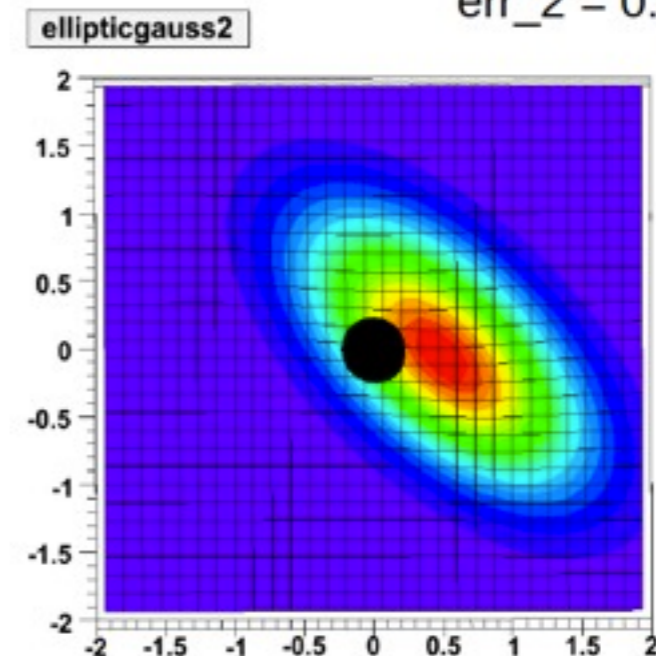

Binned Approach

- Data from detector setup with 40 of 86 strings installed
- 13 lunar months

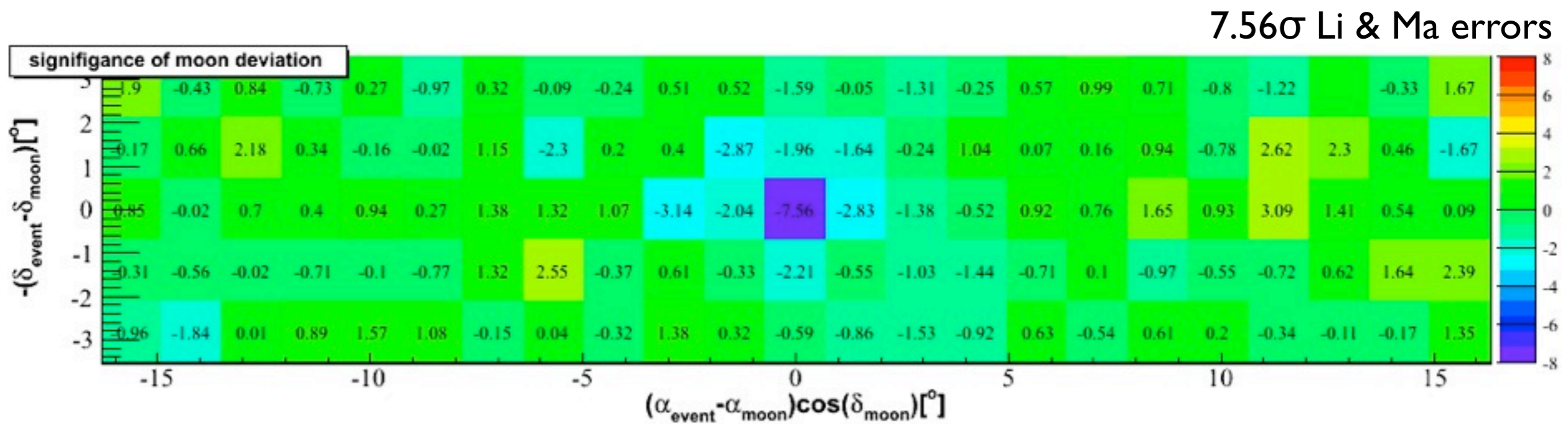
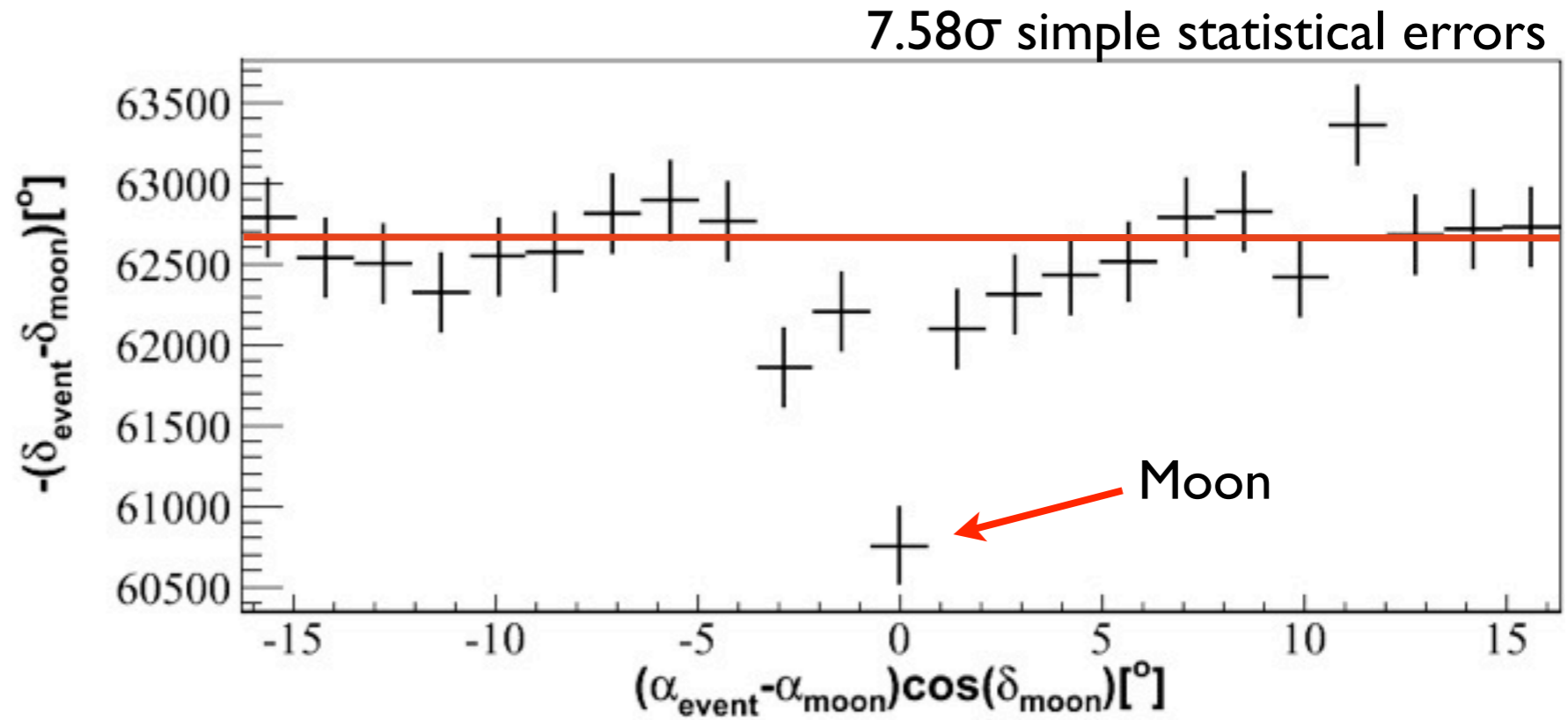

Likelihood Approach

$$L(\vec{x}_s, n_s) = \sum_i^N \log \left(\frac{n_s}{N} S_i + \left(1 - \frac{n_s}{N}\right) B_i \right)$$

- Use central signal region and off-source background region
- At each point, vary the number of events blocked by the Moon, n_s
- Maximize likelihood

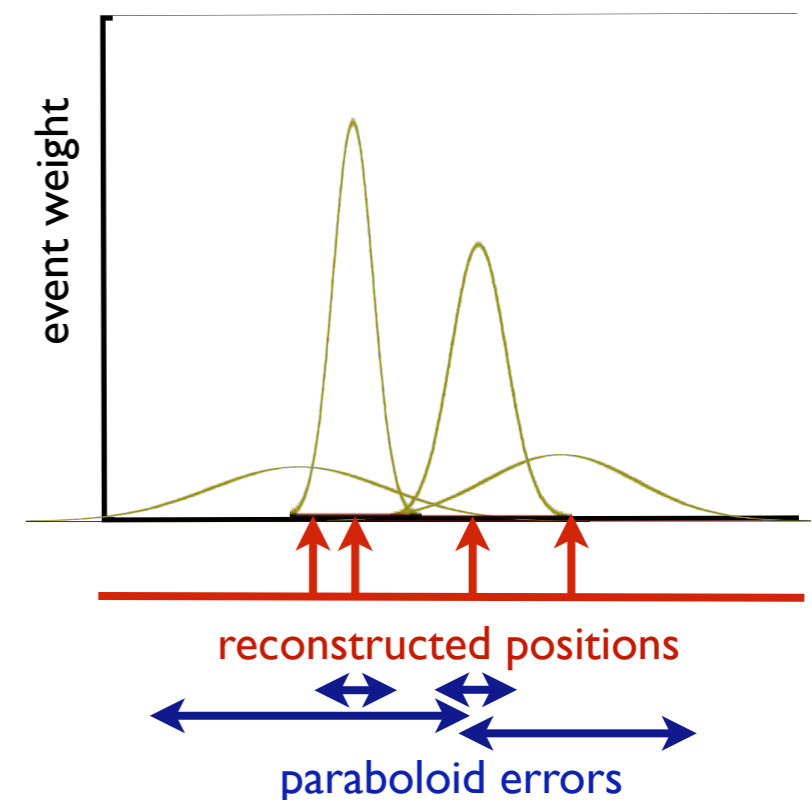
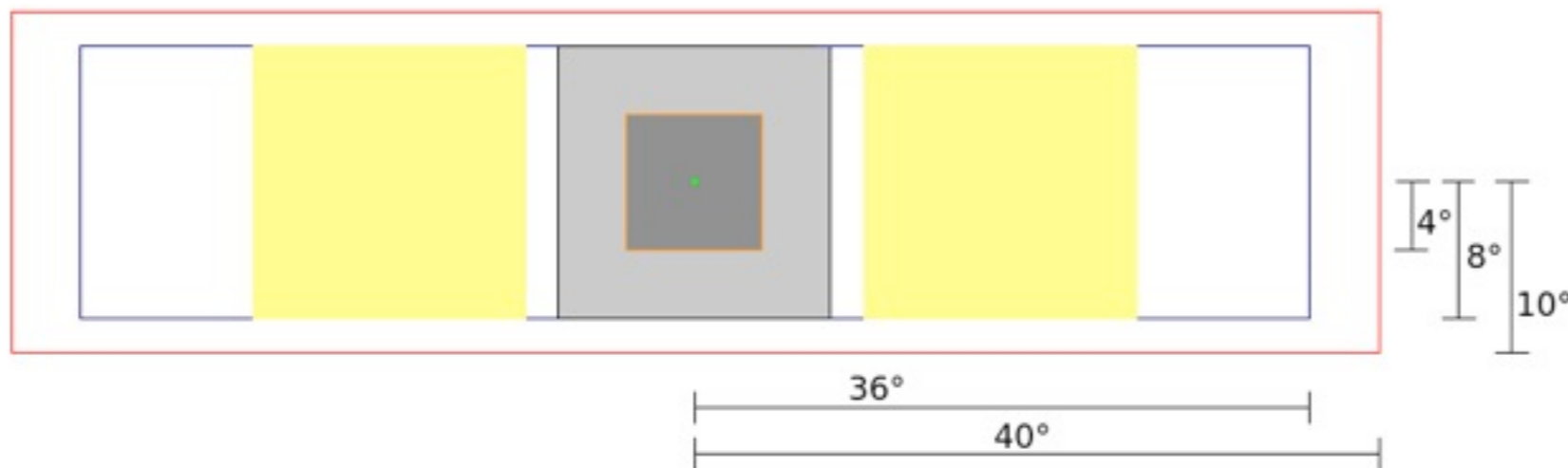

Background for likelihood

Background measured in off-source region:

projection →

Polynomial background model in zenith and azimuth

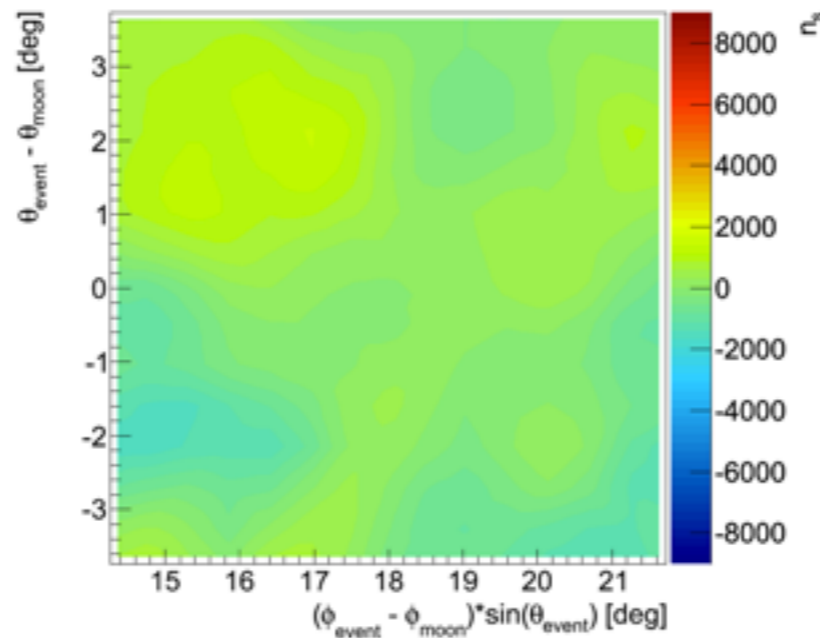
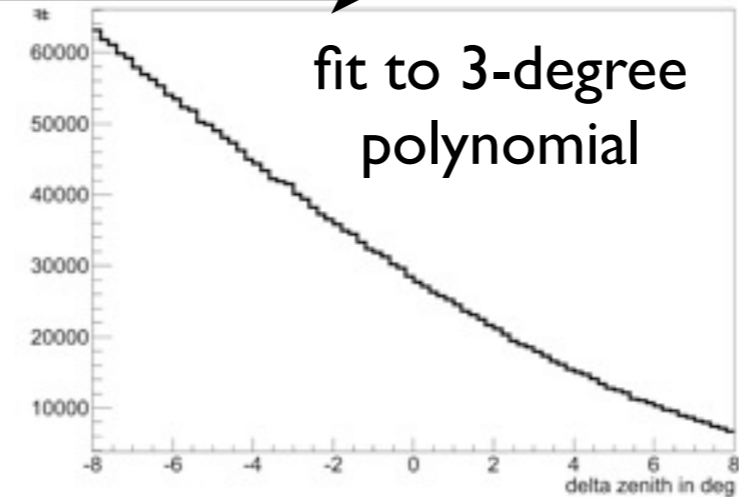
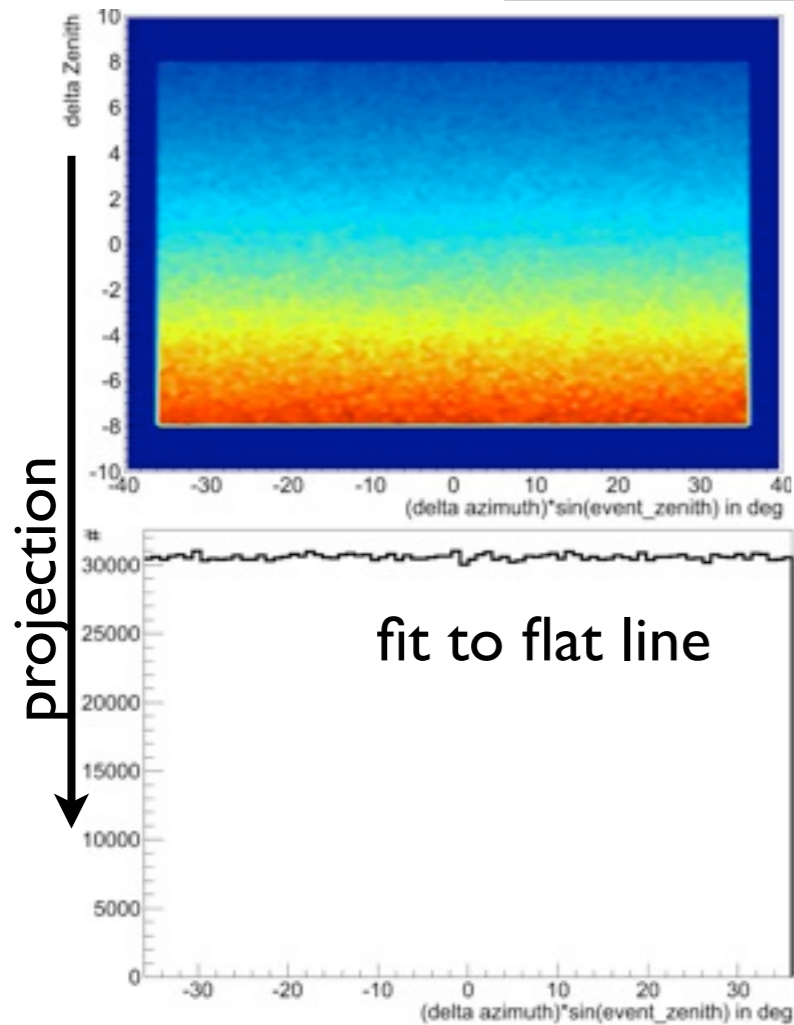

Random fluctuations around background model:

$$\sigma_{bg} = 680 \text{ events}$$

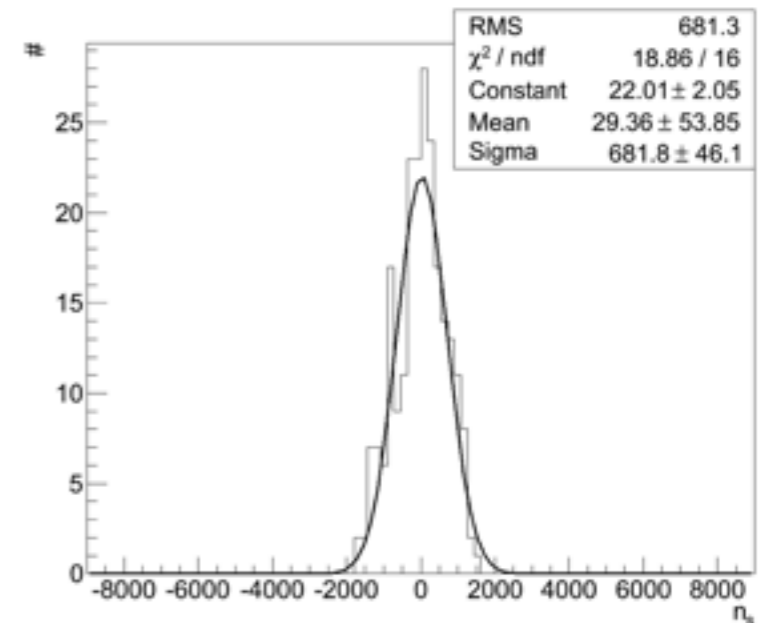

Likelihood result

PRELIMINARY

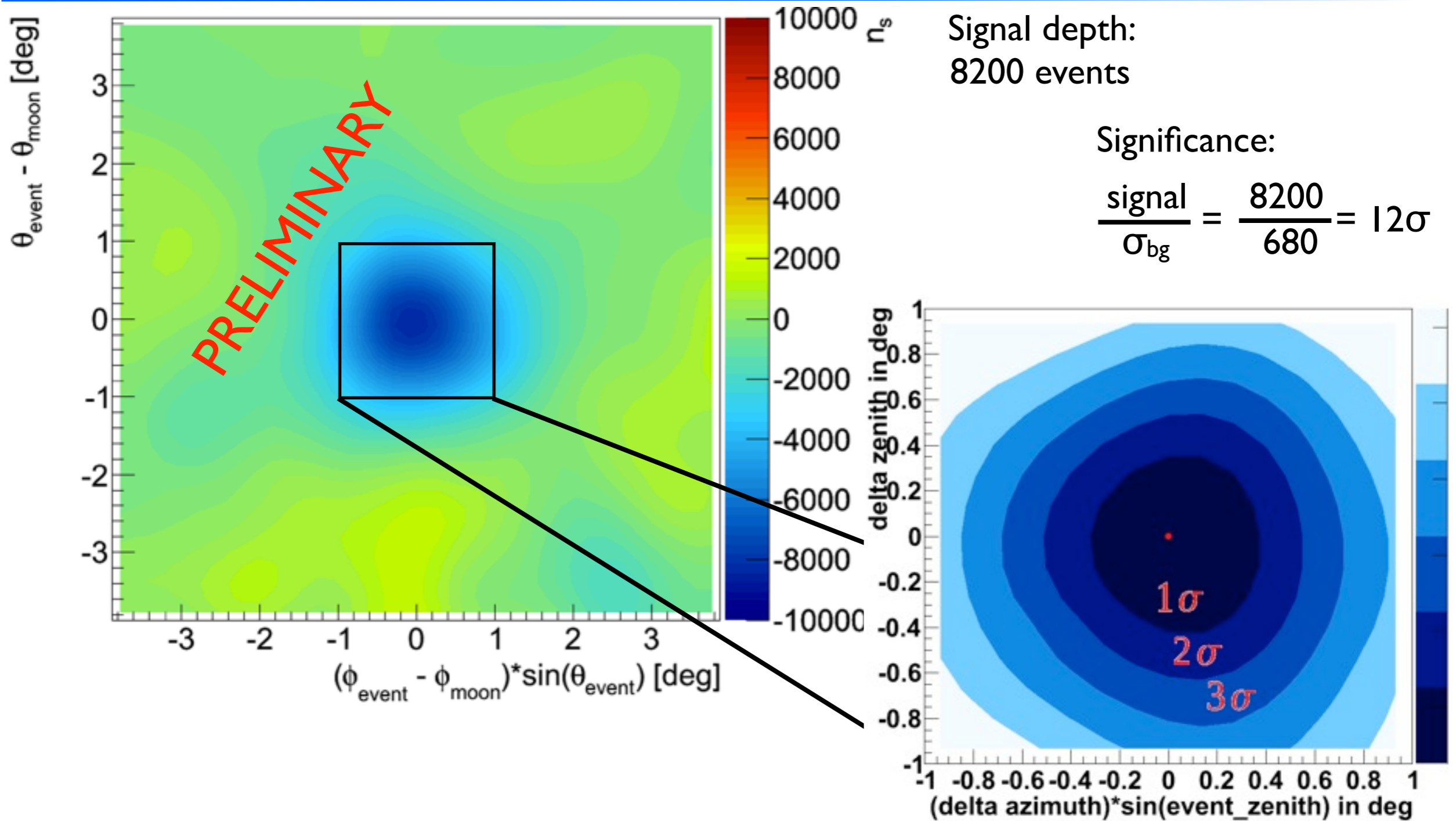

Conclusions:

- IceCube observes the Moon shadow with 12σ , confirming accurate pointing up to $\mathcal{O}(^\circ)$
- IceCube could be close to observing (extrasolar) astrophysical neutrino point sources

Thanks to the Moon Group:
J. Blumenthal, H. Stiebel,
M. Santander, D. Boersma,
C. Finley, C. Wiebusch, A. Karle

Backup:

- Binned Search, as applied to IC40
- Unbinned Search as applied to IC40



yes, I have been to the South Pole.



IC40 Data set

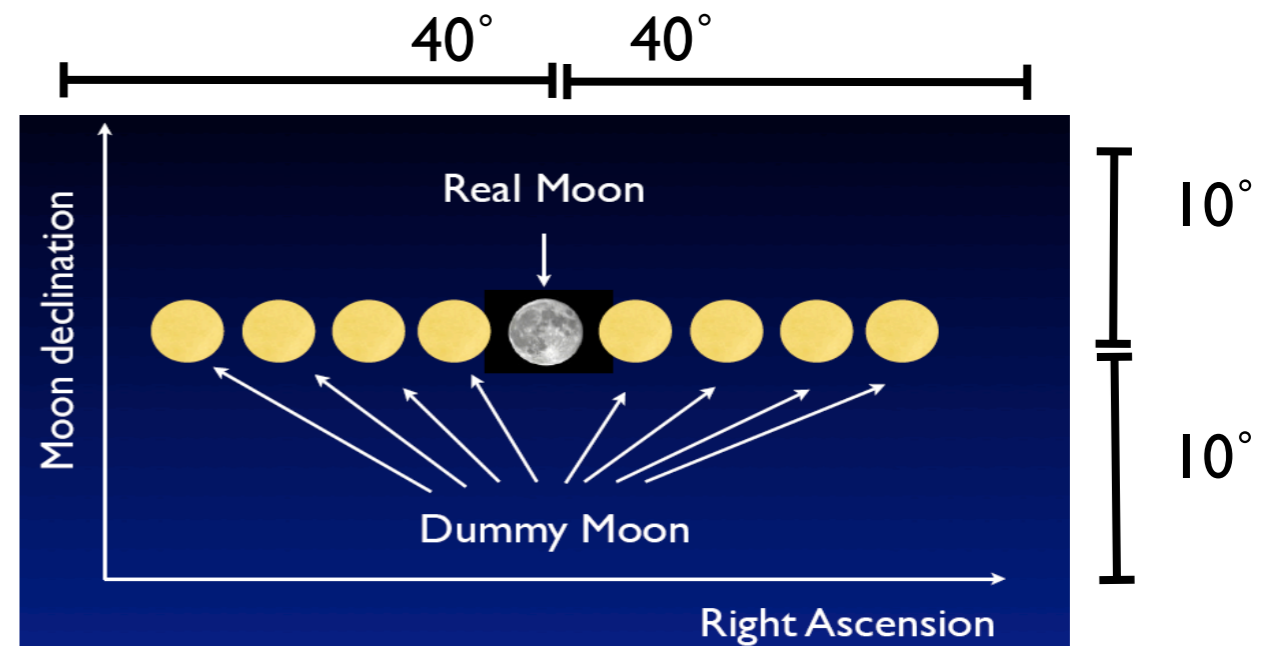
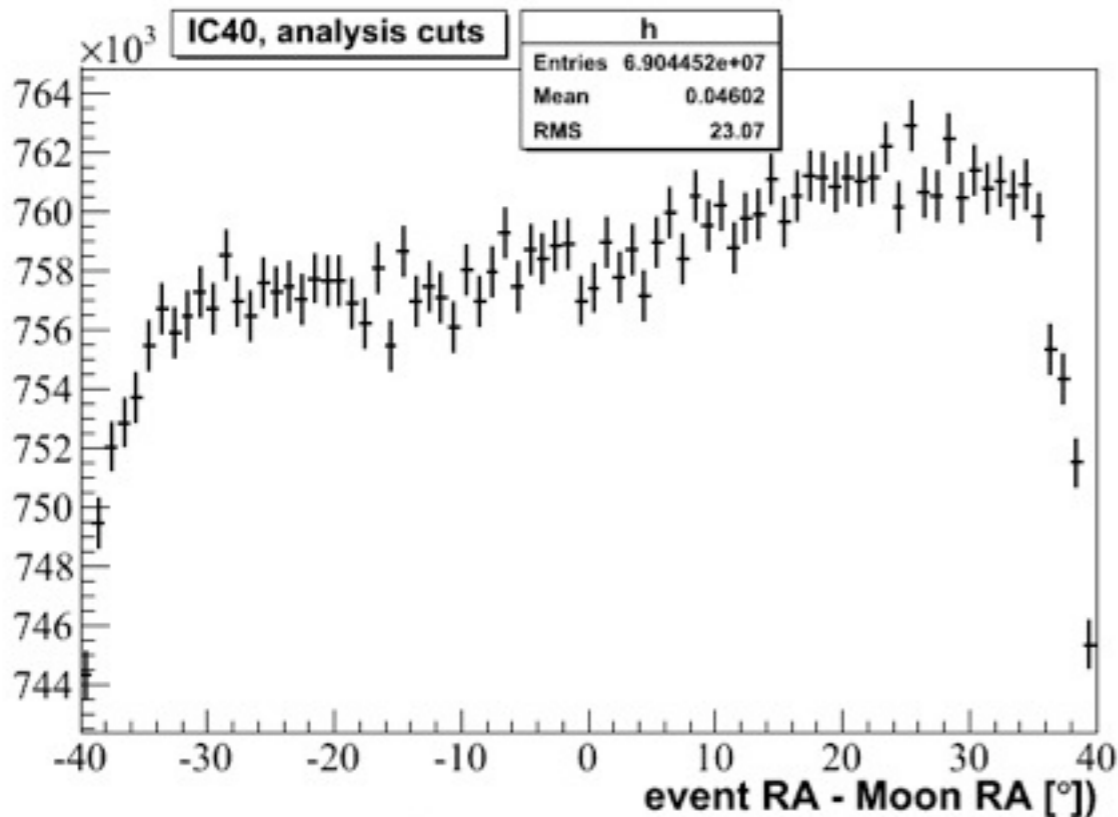
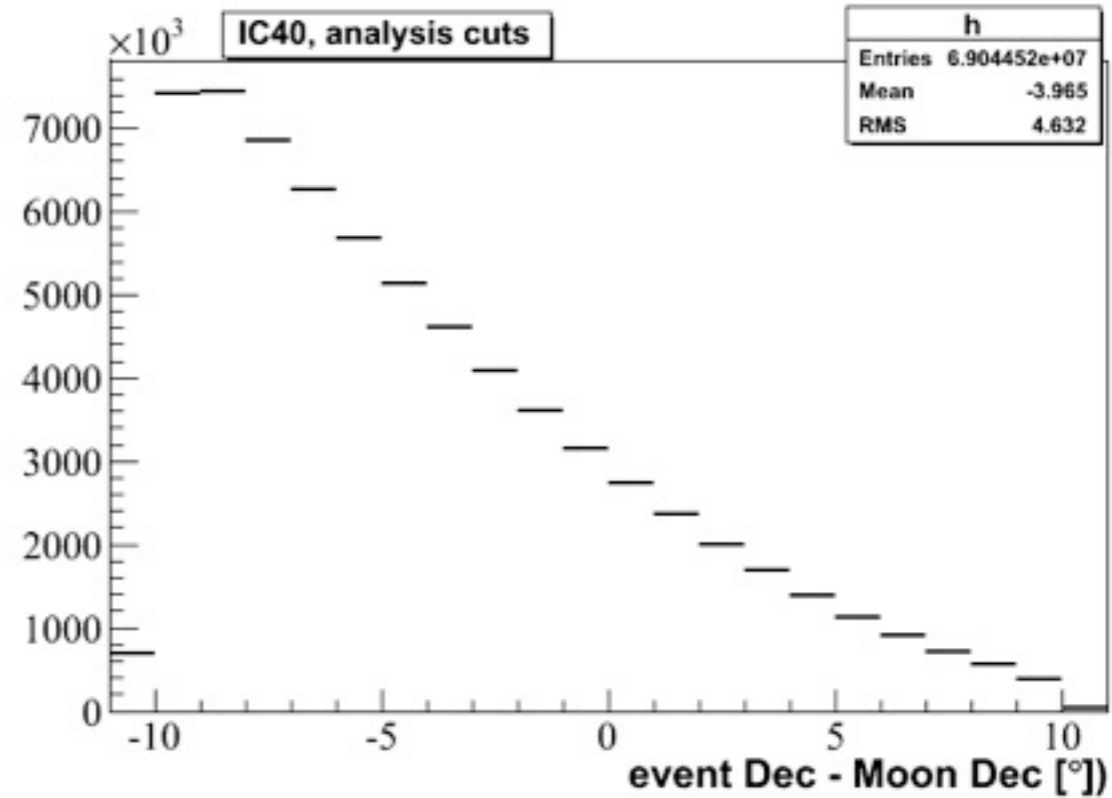
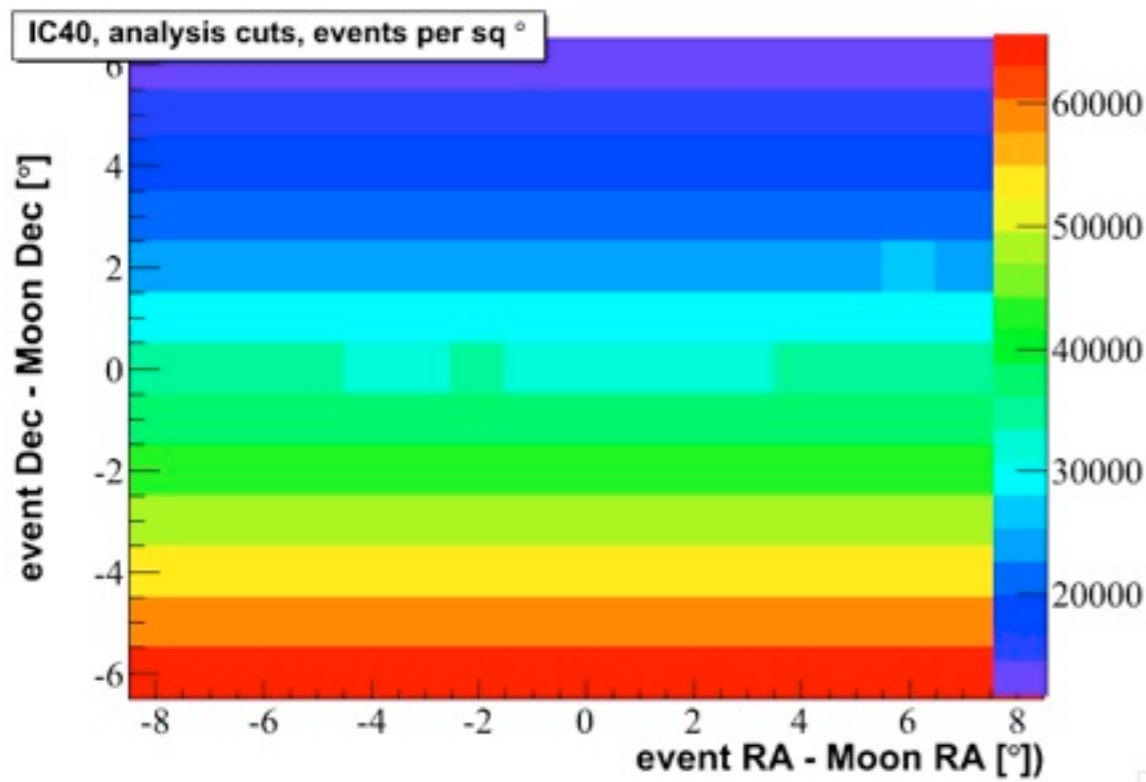

IC40 Binned Search Cuts

12 / 9

- Filter-level cuts:
 - (number of hit DOMs) \equiv NCh \geq 12
 - (number of hit strings) \geq 3
- Analysis-level cuts:
 - estimated angular error of reconstruction $\leq 1.6^\circ$
- Resulting sample:
 - 69M events, 53% efficiency from filter
 - median angular resolution: 1.27°
- Search Bin Size: 0.8°

Search bin size optimization

13 / 9

Signal: use simulated point spread function

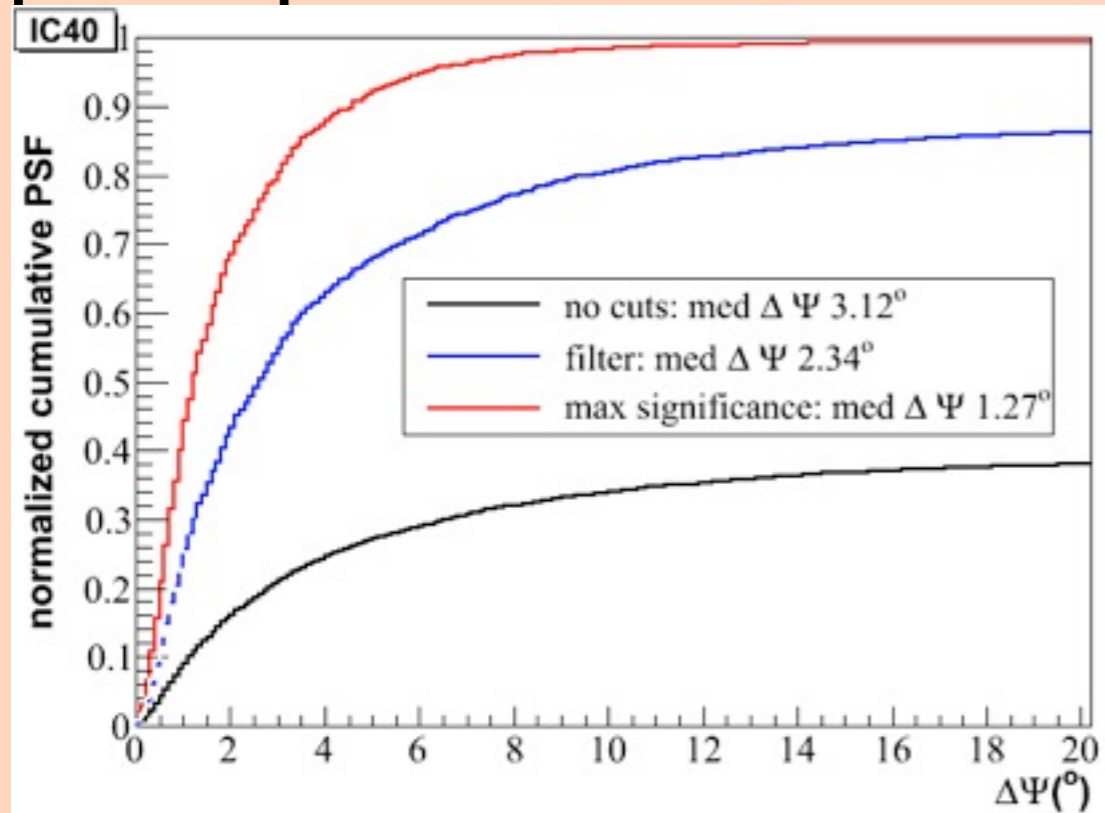

$$\text{significance} \sim \frac{N_{sig}}{\sqrt{N_{bgd}}}$$

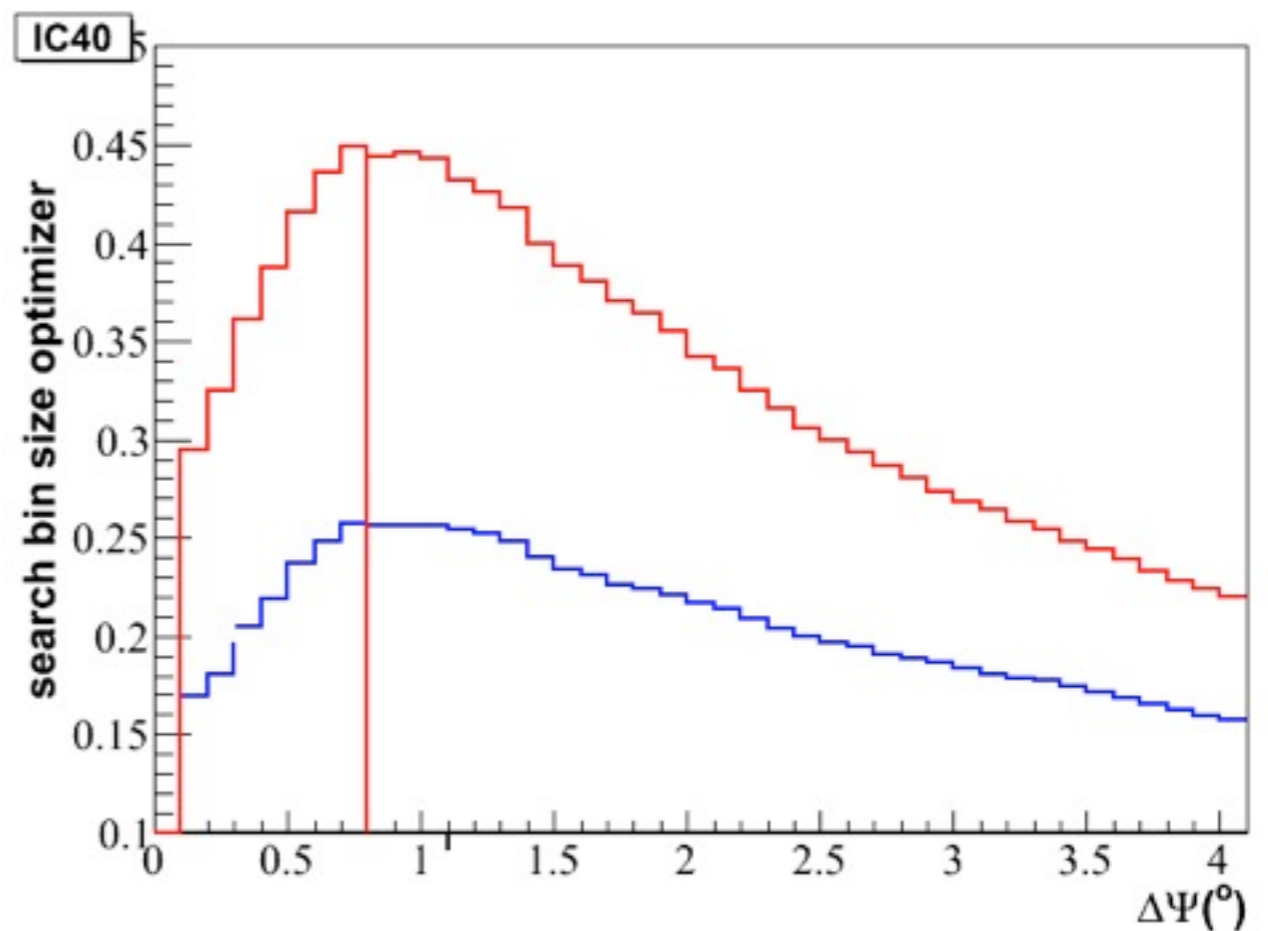

Background: scales with area

$$N_{bgd} \propto \text{Area} \propto \pi r^2$$

$$\sqrt{N_{bgd}} \propto r$$

Expect best result with search bin of 0.8°

Back-of-the-Envelope Significance 14/39

- Observe rate: 35k events/ sq°
- 70.4k in each background bin
- 7k events blocked by Moon
- Search bin contains 35% blocked events

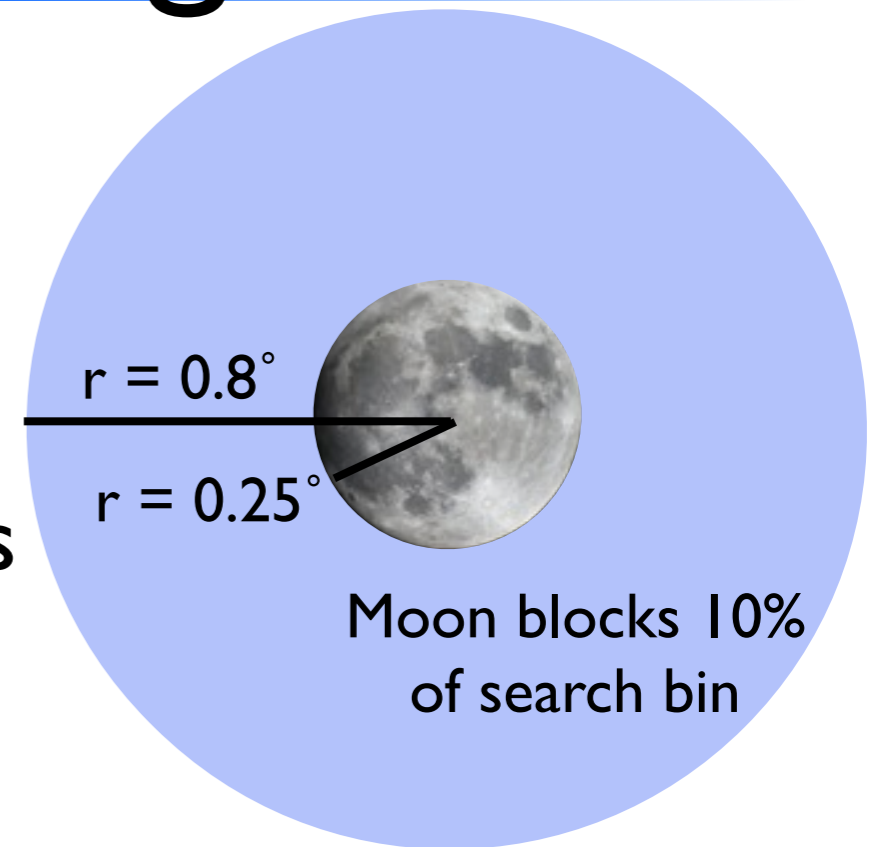

$$S = \sqrt{2} \left\{ N_{\text{on}} \ln \left[\frac{1 + \alpha}{\alpha} \left(\frac{N_{\text{on}}}{N_{\text{on}} + N_{\text{off}}} \right) \right] + N_{\text{off}} \ln \left[(1 + \alpha) \left(\frac{N_{\text{off}}}{N_{\text{on}} + N_{\text{off}}} \right) \right] \right\}^{1/2}$$

**Expect 2500 event deficit:
8.9 σ**

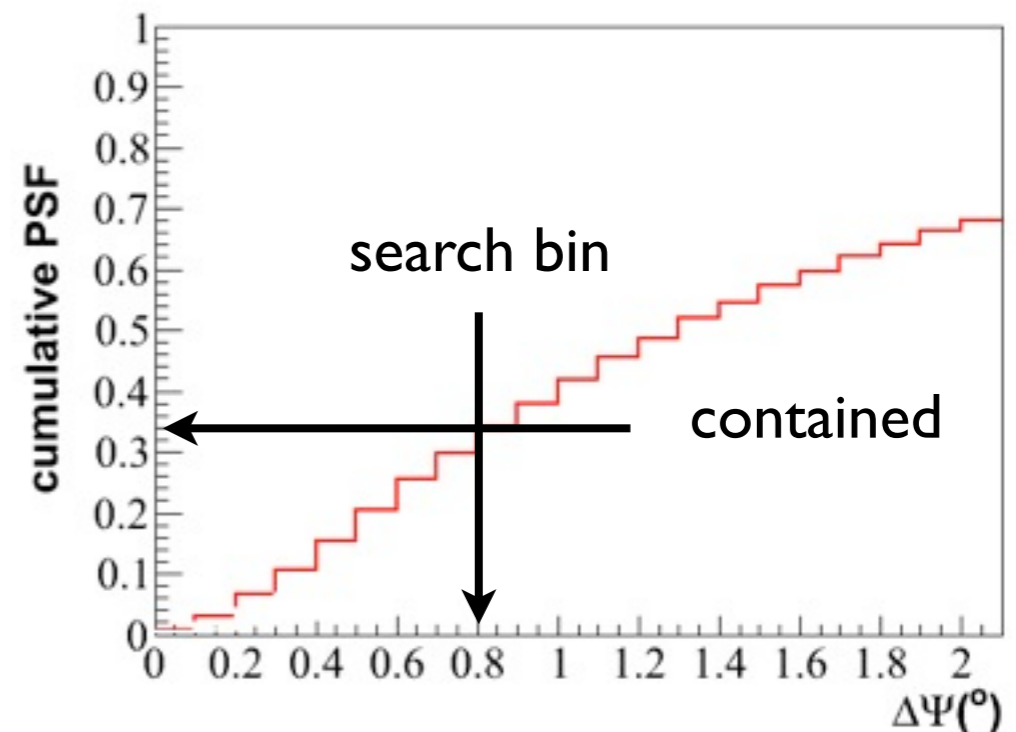

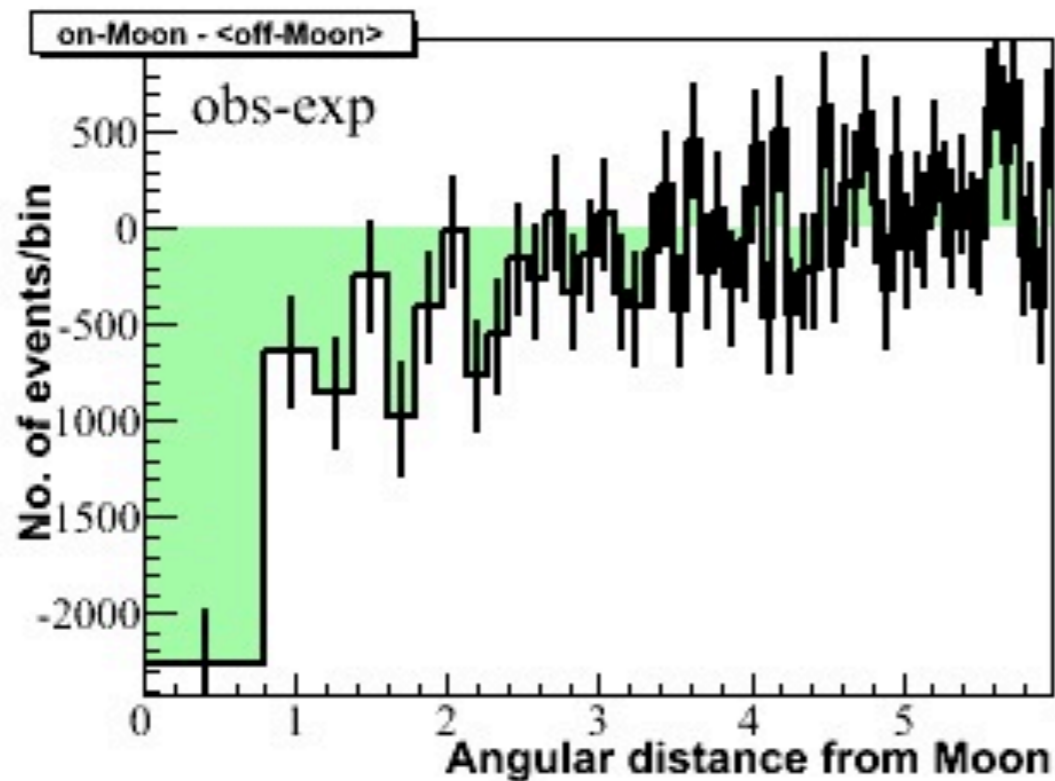
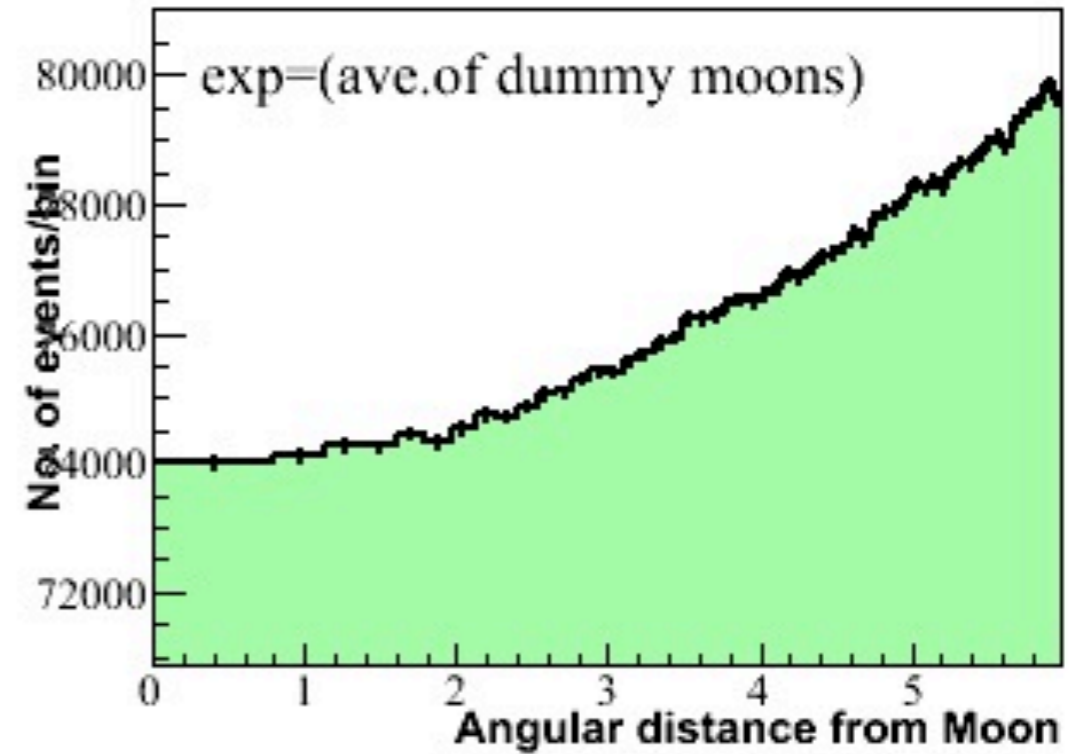
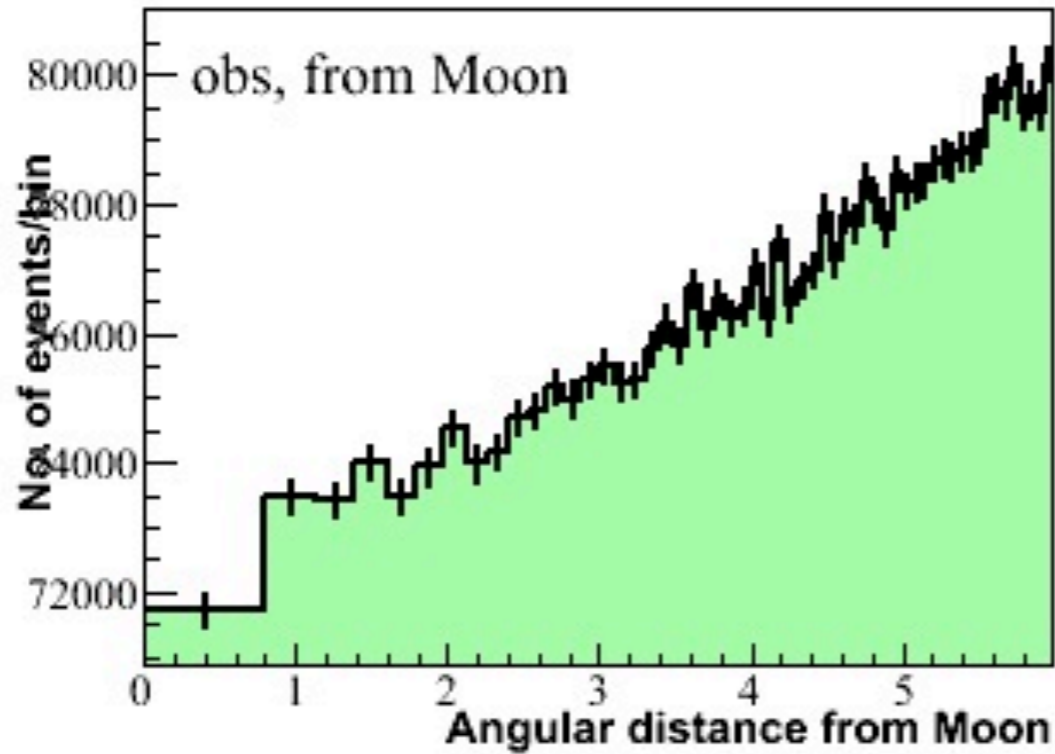

observed: 7.173×10^4 events

expected: 7.4×10^4 events

deficit: -2262 events

error: 285 events

significance: -7.9σ

Alternate Binned Method

- Consider several declination bands:
- Use off-Moon bands to correct Moon band RA structure
- This was tried on IC22

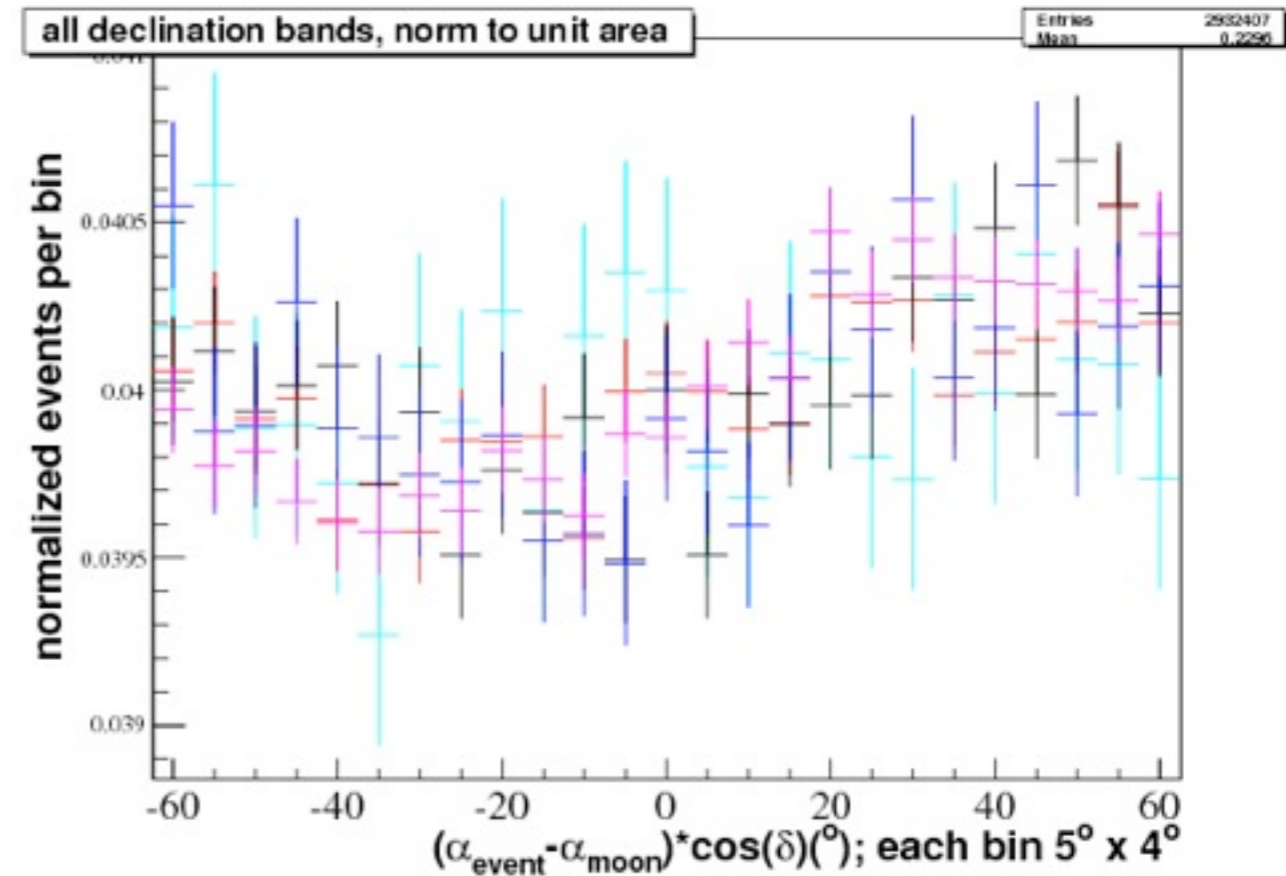
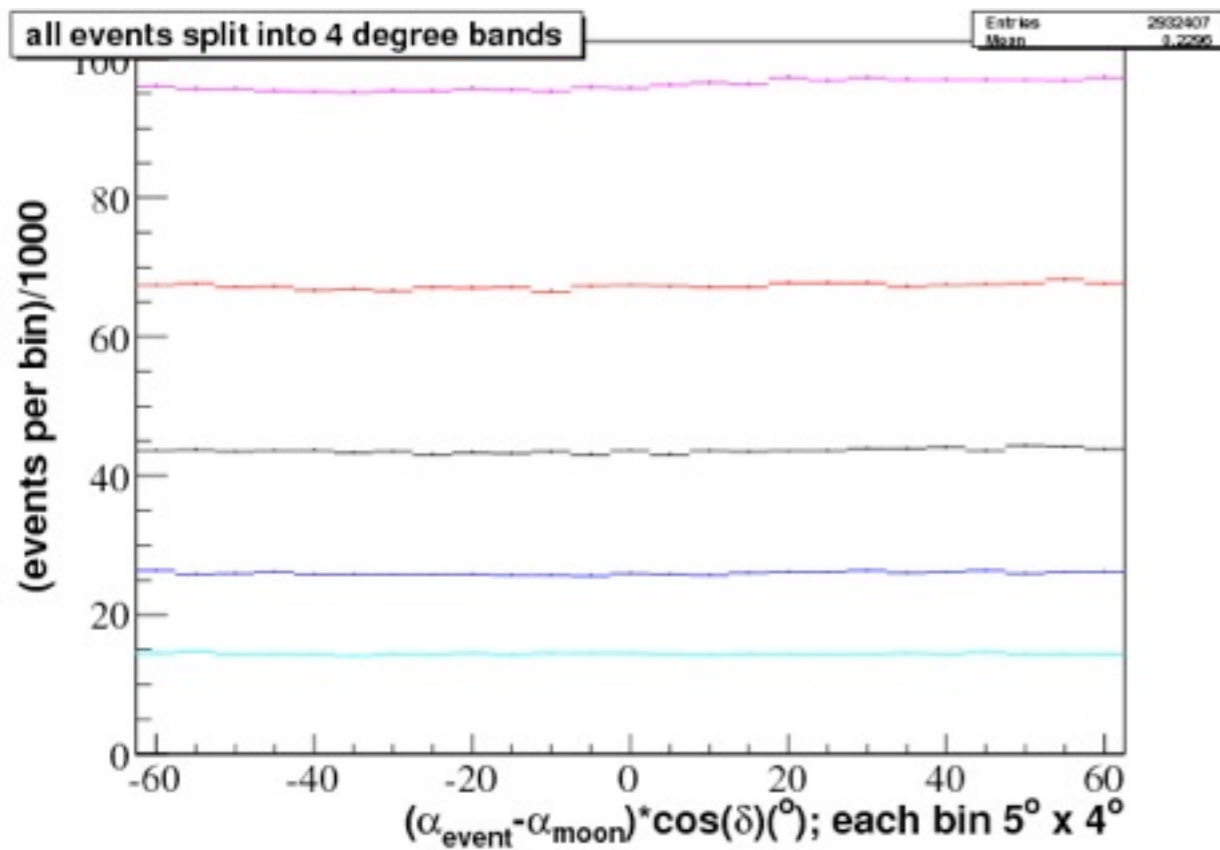

It didn't work well enough with IC22,
and with IC40 a simpler binned analysis was good enough

Does Geomagnetic field matter? ^{17/9}

- filter level cuts, zenith $> 50^\circ$

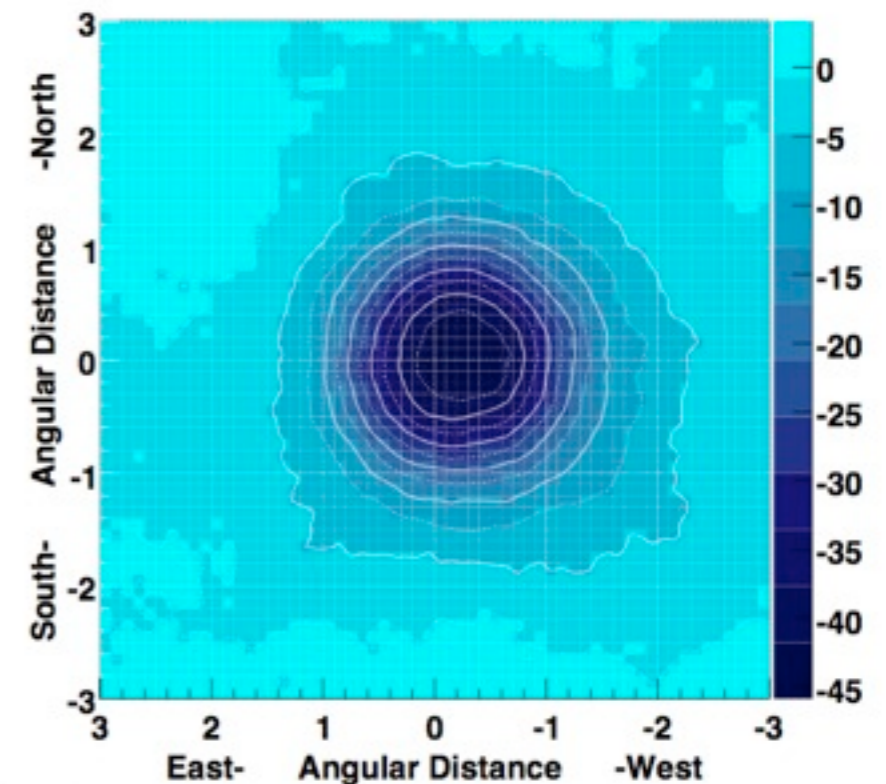
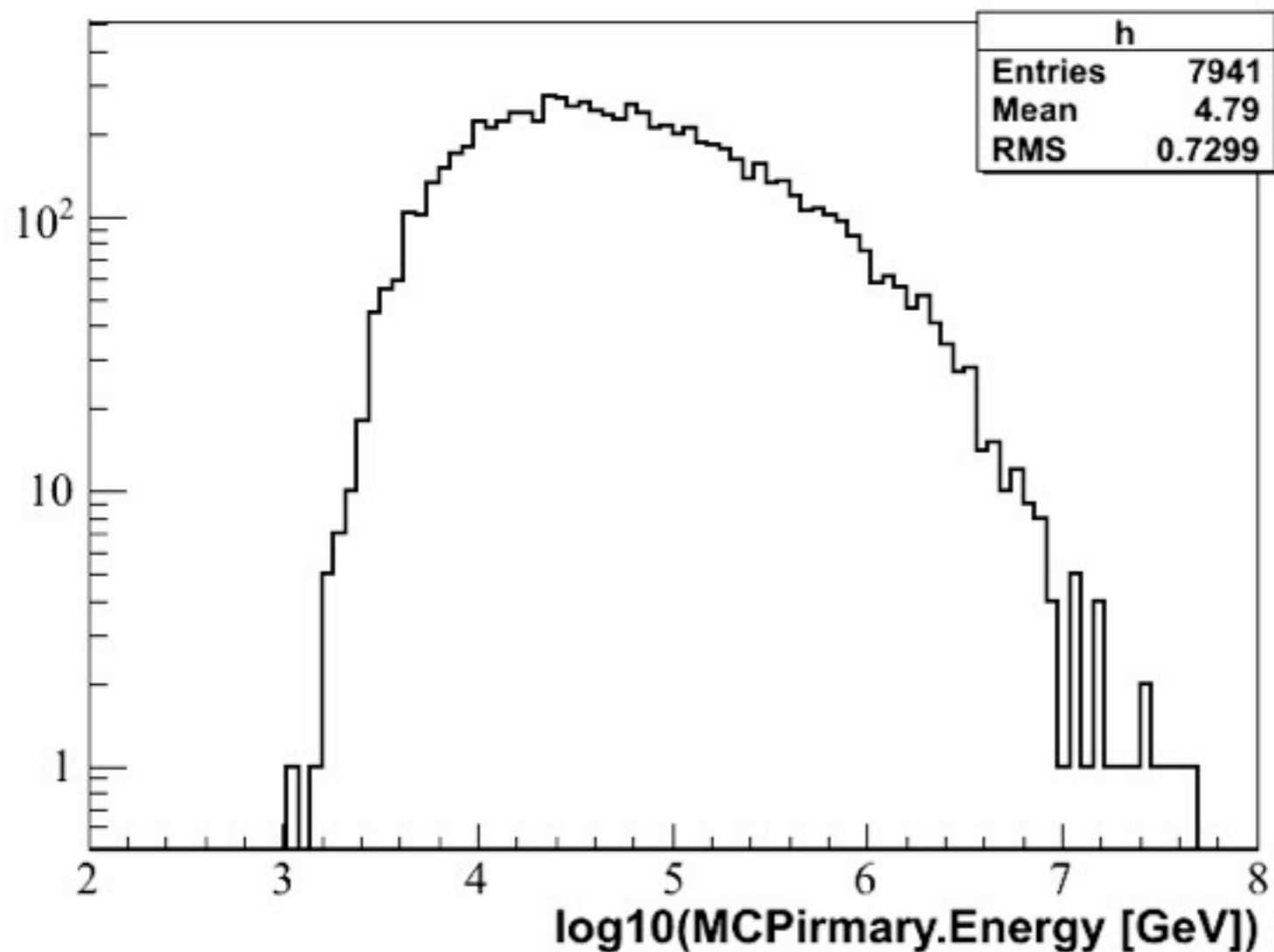

Shift from magnetic fields is negligible
Tibet Air Shower Array
[arXiv:0810.3757v1](https://arxiv.org/abs/0810.3757v1) [astro-ph]
I-40 TeV

→ shift is also negligible in this analysis

Approach II: Unbinned skymap 18 / 9

Smear each event by its paraboloid error
Map the total weighted event sum

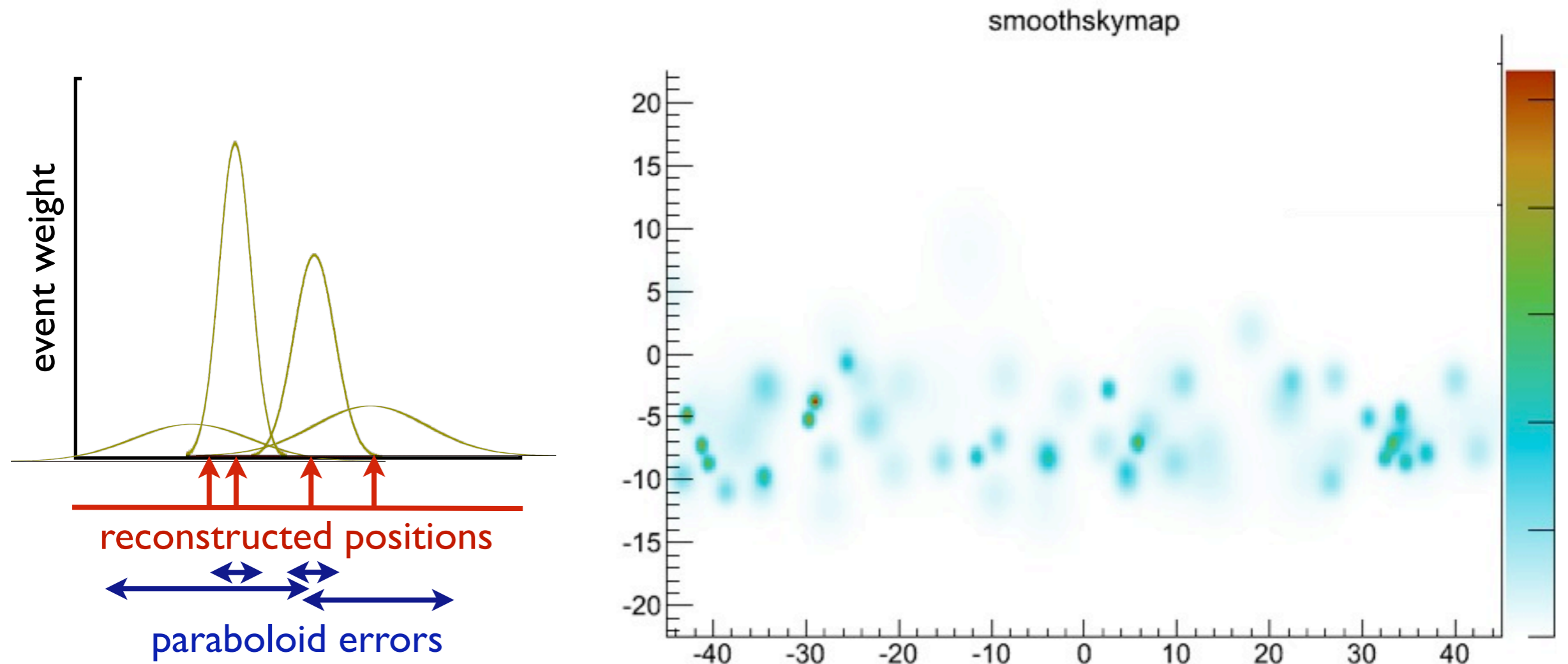

Unbinned Skymap

- Healpix: program for skymaps-- uses equal-area bins
- Box-shape is from filter window
- Gradient from zenith dependence of CR flux
- Draw Moon centered at its average position

